



Bi-fold Door System Set F400

Flexible space-savers

Create style and definition with bi-fold room partitions. Maximise space and de-clutter communal areas with hidden laundries and wardrobes.





For top-hung folding door systems

In conjunction with the T-type Hinge, Set F400 provides a soft-closing folding door system without a bottom running track. Ideal for room dividers, kitchen pantry and appliance cupboards, walk-in cupboards, wardrobes and walk-in robes, and partitioned laundry applications.

The 30kg load capacity per door offers the flexibility to use a variety of door panels to create the perfect style to suit your application. When used with the Titus T-type Glissando hinge, you can be confident that the Titus proprietary damping technology will ensure smooth and consistent soft close action for the lifetime of the hinge.

The T-type hinge's innovative 3Way snap-on hinge-to-plate mounting system enables quick and easy installation, particularly for tall doors, for an all-round intuitive and user-friendly assembly.

Set F400 Bi-fold Door System

For top hung
sliding door systems

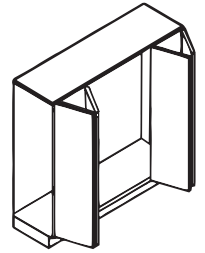

- Top-hung
- Kitchen cabinet bi-fold
- Room divider



Item number for a set	2 Hinge Kit	5 Hinge Kit
608.8V02.518 →	102	105
One set consists of		
Upper roller	1 set	1 set
1800mm aluminium top track	1 length	1 length
Centre hinge	2 pcs	5 pcs
Track template	1 pc	1 pc
Mounting instructions	1 pc	1 pc

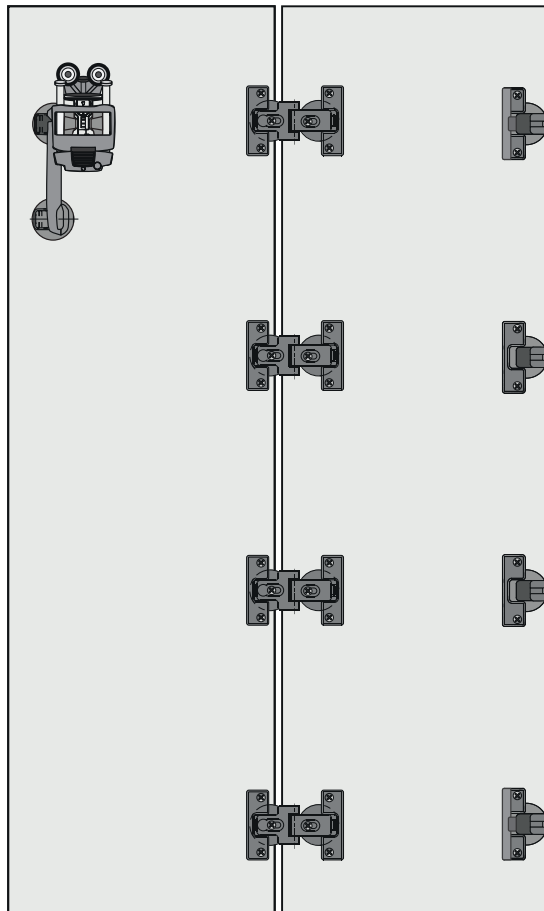

Cabinet hinges not included.



**T-type Glissando
110 Hinge**
→ see page
2.24 of Technical
Catalogue



**T-type 110
Hinge**
→ see page
2.32 of Technical
Catalogue



**T-type Mounting
Plates**
→ see page
2.44 of Technical
Catalogue

- Door weight Max. 30kg
- Door width Max. 500mm
- Door height Max. 2400mm
- Door thickness Max. 25mm

Mounting details

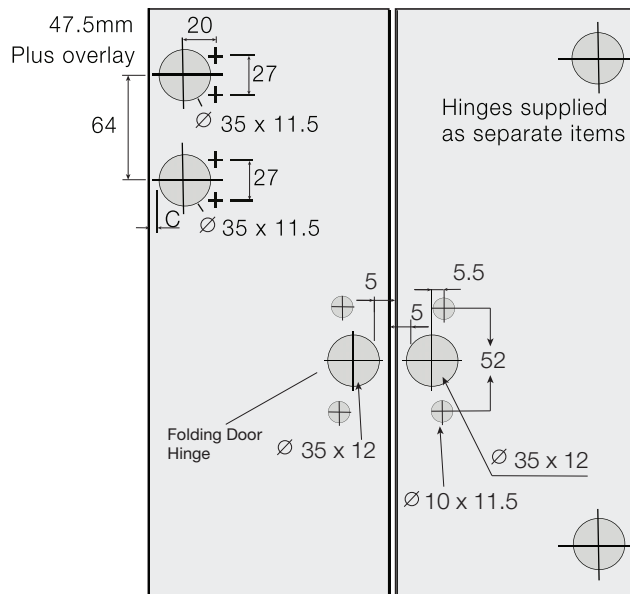

Door drilling pattern

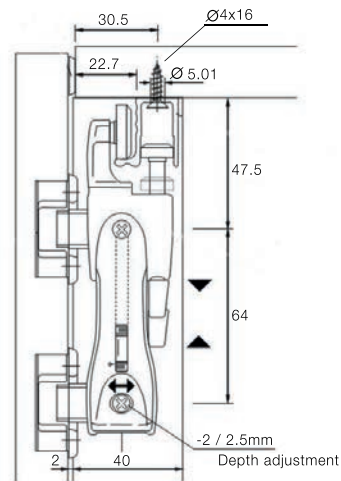

For information on choosing the correct number of cabinet hinges for your application, please refer to the Technical Product Catalogue or speak to a Technical Sales Representative.

Titus T-type Hinge

Set F400 is compatible with the Titus T-type Hinge for consumer-preferred 'ConfidentClose' soft closing motion

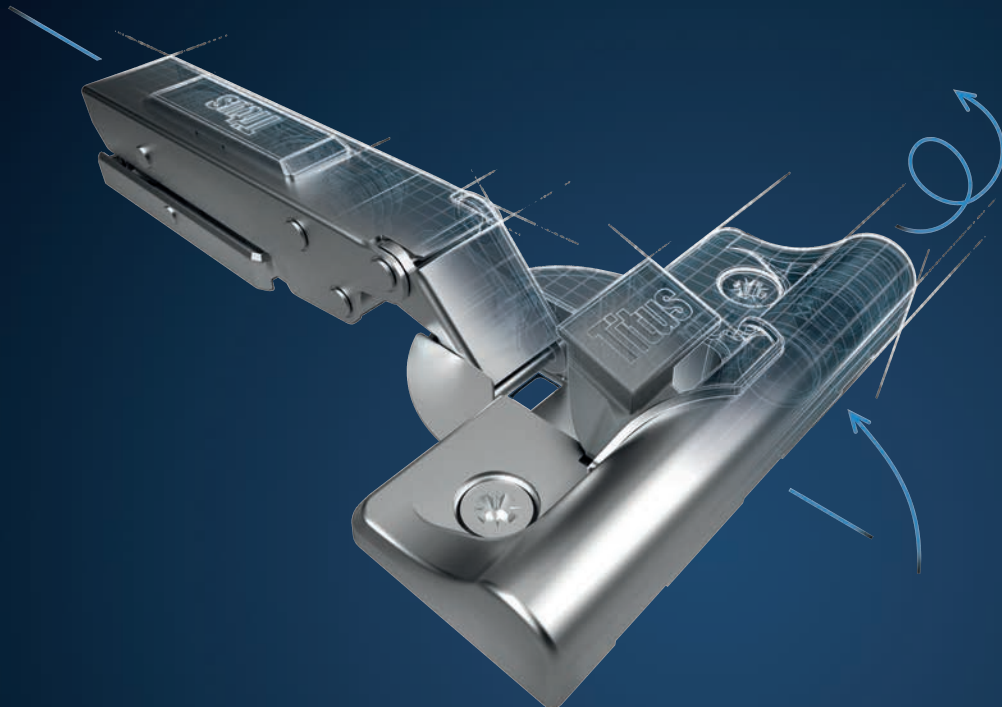

- The fastest assembly for tall cabinets with '3Way' snap-on mounting, ideal for applications where several hinges per door are required
- Backed by lifelong consistent 'Confident Close' performance
- Shallow hinge cup for consistent performance on doors of different dimensions and weights

T-type Hinges and Mounting Plates

For wooden doors

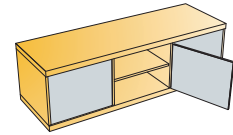
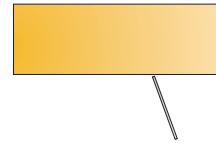
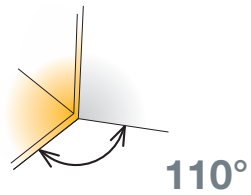

- Opening angle
- Drilling diameter for hinge cup
- Drilling depth
- Hinge on plate mounting system

110°
35mm
11.7mm
'3Way' snap-on

	Technical details	Interaxis 45mm
Cup type	Item number	

T-type Glissando 110

0mm

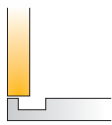

Made of steel

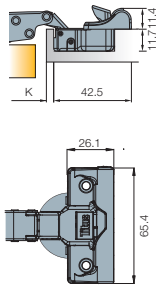

- 701.0AT0.054.00
- 701.0AT1.054.00
- 701.0AT4.054.00

For technical specifications and drilling patterns for hinge cups, refer to our Complete Technical Catalogue.

T-type 110

0mm

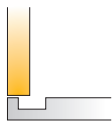

Made of steel

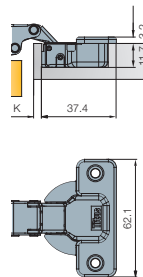

- 702.0AK0.054.00
- 702.0AK1.054.00
- 702.0AK4.054.00

For technical specifications and drilling patterns for hinge cups, refer to our Complete Technical Catalogue.

Cam Adjustable Cruciform Mounting Plate 37mm



Made of steel

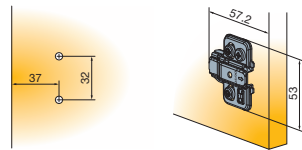

Cam Adjustable Linear Mounting Plate



Made of steel and zinc

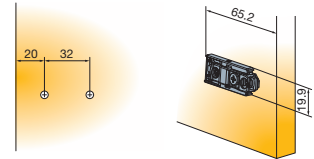

Mounting plate type	15		10.5	Mounting plate type	15		10.5
Mounting plate thickness (D)				Mounting plate thickness (D)			
Item number	Item number	Item number	Item number	Item number	Item number	Item number	Item number
0mm	700.0KC0.054.00	700.0KA0.054.00	700.0KF0.054.00	0mm	700.0LB0.054.00	700.0LF0.054.00	
2mm	700.0KC2.054.00	700.0KA2.054.00	700.0KF2.054.00	2mm	700.0LC2.650.00	700.0LB2.054.00	700.0LF2.054.00
3mm	700.0KC3.054.00	700.0KA3.054.00	700.0KF3.054.00	3mm	700.0LC3.650.00	700.0LB3.054.00	700.0KA3.054.00

Legend of mounting plate type symbols





Titus Tekform Australia

www.titustekform.com.au

info@titustekform.com.au

 1300-0-TITUS

Stefano Orlati New Zealand

www.stefano-orlati.com

stefano-orlati@titusplus.com

Connect with us



[LinkedIn.com/company/titustekform](https://www.linkedin.com/company/titustekform)



[Instagram.com/titustekform](https://www.instagram.com/titustekform)



[Pinterest.com/titustekform](https://www.pinterest.com/titustekform)



[YouTube.com/watch?v="Titus Tekform"](https://www.youtube.com/watch?v=)